

NEW METHOD OF CATALYST OBD ASSESSMENT TO SUPPLEMENT THE CURRENT OBD2 METHOD BY MEASURING RESISTANCE OF HEGO HEATERS FORE AND AFT A CATALYST CAN

Seha Son

Ford Motor Company
Dearborn, Michigan, USA
(sson@ford.com)

ABSTRACT

A new method to replace or supplement the current OBD2 system, utilizing existing hardware with no extra variable cost, is developed and demonstrated experimentally. By comparing the resistance values of HEGO heater resistances before and after the catalyst, one can assess the performance of the catalyst in between.

I. INTRODUCTION

HEGO sensor heater electrical resistance is a function of its own temperature [1]. Accordingly, an attempt is made to demonstrate a new method to replace or supplement the current OBD2 method, utilizing existing hardware. The exhaust gas leaving a fresh or good catalyst will be at higher temperature than those leaving a poor catalyst (including blank and no catalyst), provided that all other conditions are equal [2, 3]. This exhaust gas at higher temperature will place the rear HEGO sensor heater at higher temperature resulting in higher resistance.

II. EXPERIMENT

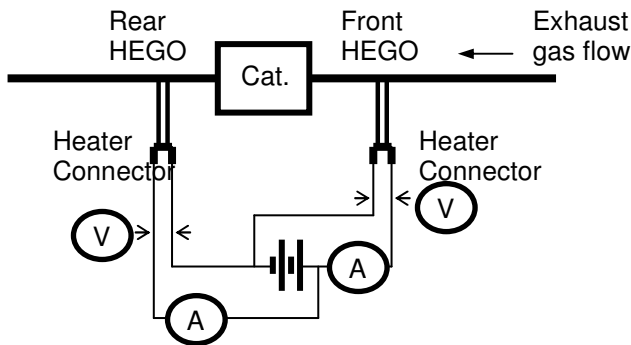

Figure 1 Schematic of the measurement of heater resistance

Catalyst	Aging/Poison Level
Blank Catalyst	N/A
10hr+10%P	10hr Oven @1200°C+10%P
6hr+5%P	6hr Oven @1200°C +5%P
2hr+2%P	2hr Oven @1200°C +2%P
Fresh Catalyst	N/A

Table 1 List of catalysts - %P in weight

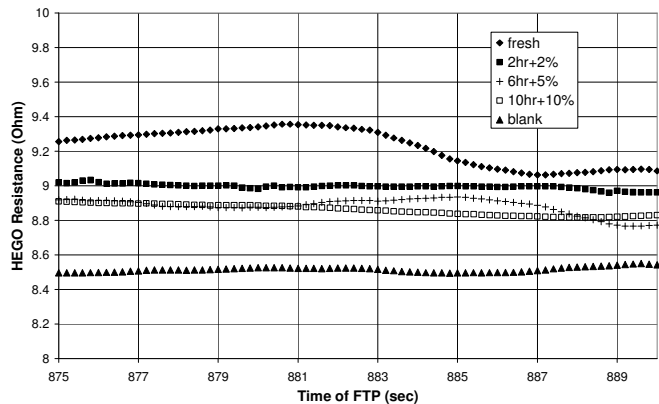

Figure 2 Rear HEGO heater resistance between 875 and 890 second of a FTP drive cycle

REFERENCES

1. S. Son, "Exhaust Gas Temperature Determination with HEGO parameters", SAE 2010-01-1303
2. S. Son, "Non-Invasive Differential Thermocouple Method for the Evaluation of Catalyst Performance", SAE 2008-01-0454
3. S. Son, "A simplified method to make temperature measurements of a metal surface using the surface as one component of thermocouple", SAE 2008-01-0918